

Midland Handling Equipment Ltd

STRETTON ROAD, GREAT GLEN, LEICESTER. LE8 9GN

Telephone 0116-2593175 Fax 0116-2592820

E-mail enquiries@mhel.co.uk



Trakmaster 152 Light/medium duty

Data Sheet

Chain

Fully bi-planer and assembled in our works from hardened steel side links, rivets and hardened ball bearing wheels. The chain is immersed in protective lubricant after assembly. Breaking strain 3000 lbs (1340kg), safe load **13.4kg** per pendant at 152mm pitch - **26.8kg** per coupled pendant. Maximum chain breaking strain is 3,000 lbs.

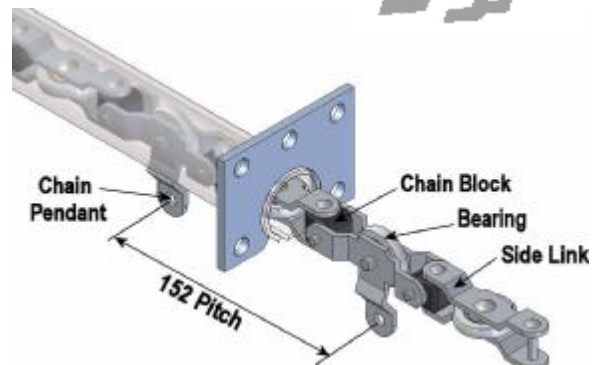

Track

High quality mild steel galvanised tubular section 41mm o/d with 3mm wall thickness with an offset slot. Track curves manufactured from cold drawn seamless steel tube, the slot machined in and hardened.

Drive

In line 6 tooth main chain sprocket with hardened tooth form driven via a torque limiter, gearbox and DC or AC motor operating on a 240v single phase 50hz supply. All drives have variable speed via an inverter or a controller. 8 tooth corner drives are available (90 and 180 deg).

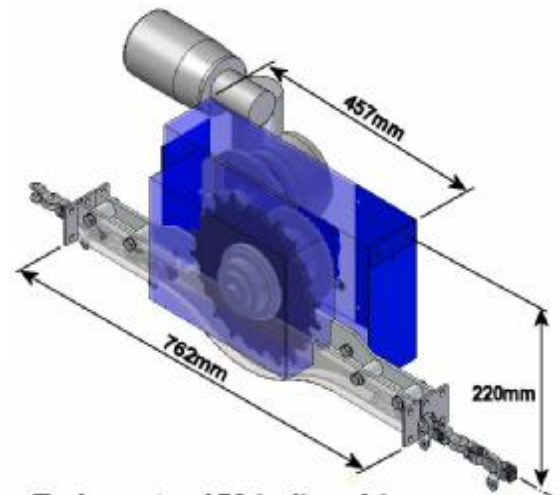

Trakmaster 152 in-line drive

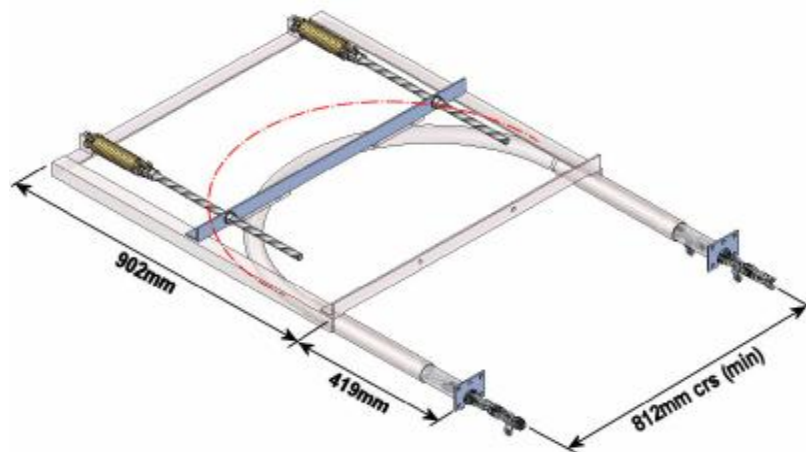

Tension

A spring loaded tension device would be fitted to ensure correct chain tension and to compensate for variances within the system.

Inspection

This would be incorporated in a readily accessible position in the circuit for inspection and preventative maintenance.

Support Structure

The conveyor would be either floor supported using square hollow section forming a rigid structure and incorporating base plates, or roof supported utilising track hanger clamps connected to tubular suspensions. Please see specification for specific proposals.

Carriers

Please see specification for details. The conveyor incorporates pendants at 152mm pitch.

Finish

Track galvanised, steelwork finished mid blue paint, machined parts self colour.

